



CURRICULUM FRAMEWORK

BACHELOR OF SCIENCE IN ELECTRICAL ENGINEERING

Electrical and Computer Engineering program

PROGRAM CODE: 7520201

Applicable for the intake beginning in 2023 - 2024

*(Released along with Decision No. 88/2024/QĐ-VUNI dated February 27th, 2024, by
Provost of VinUniversity)*

***This curriculum framework has been reviewed and validated
by Cornell University***



Table of Contents

1. VINUNI GENERIC GRADUATE ATTRIBUTES	3
2. PROGRAM EXPECTED OUTCOMES	3
2.1 Program Profile	3
2.2 Program Purpose	3
2.3 Program Educational Objectives and Student Outcomes	4
2.3.1 Program Educational Objectives	4
2.3.2 Student Outcomes	4
3. CURRICULUM STRUCTURE	5
3.1 Curriculum Composition	5
3.2 Courses and Credit Distribution by Courses	6
3.3 Curriculum Planner	10
3.4 Course Descriptions	13

1. VINUNI GENERIC GRADUATE ATTRIBUTES

Generic graduate attributes are a set of skills, attributes, and values that all learners should achieve regardless of discipline or field of study; should be measurable and broad. The five Generic Graduate Attributes for VinUni, framed around the EXCEL Model, are listed as below:



2. PROGRAM EXPECTED OUTCOMES

2.1 Program Profile

Name of the degree	Bachelor of Science in Electrical engineering
Name of the program	Electrical and Computer Engineering (ECE)
Program duration	to be completed in 4 years on a full-time basis
Total credits	Option 1 Single major: 123 credits
	Option 2 Major + minor in Robotics or Product Design or Artificial Intelligence or another minor: 131 credits

2.2 Program Purpose

The overall aim of the program is to nurture and develop young leaders in electrical engineering with clear direction and vision, creativity and sound personal values; who pave the way for the development of science and technology, to increase labor productivity and to benefit society.

2.3 Program Educational Objectives and Student Outcomes

2.3.1 Program Educational Objectives

The educational objectives of the Bachelor of Science in Electrical Engineering program are that within a few years of graduation, a majority of our graduates will demonstrate excellence in top graduate programs; or in technical and managerial leadership tracks in technology-based industries or other sectors; or pursuing entrepreneurial ventures. In these roles they will:

1. Apply basic knowledge of electrical engineering principles and in-depth knowledge of one area of concentration to solve a full range of technical and societal problems;
2. Conceive, design, and realize products, systems, and services, while properly respecting economic, environmental, cultural, safety, and ethical standards or constraints;
3. Be leaders with an entrepreneurial mindset, effective communicators, and informed decision makers as members of multidisciplinary teams, supporting collaborative and inclusive environments;
4. Discover and apply new knowledge, and engage in life-long learning for the profession of electrical engineering;
5. Engage with their communities, profession, the nation, and the world.

2.3.2 Student Outcomes

1. An ability to identify, formulate, and solve complex engineering problems by applying principles of engineering, science, and mathematics;
2. An ability to apply engineering design to produce solutions that meet specified needs with consideration of public health, safety, and welfare, as well as global, cultural, social, environmental, and economic factors;
3. An ability to communicate effectively with a range of audiences;
4. An ability to recognize ethical and professional responsibilities in engineering situations and make informed judgments, which must consider the impact of engineering solutions in global, economic, environmental, and societal contexts;
5. An ability to function effectively on a team whose members together provide leadership, create a collaborative and inclusive environment, establish goals, plan tasks, and meet objectives;
6. An ability to develop and conduct appropriate experimentation, analyze and interpret data, and use engineering judgment to draw conclusions;

7. An ability to acquire and apply new knowledge as needed, using appropriate learning strategies;
8. An entrepreneurial mindset and a recognition of the importance of traditional values, national pride and global awareness.

3. CURRICULUM STRUCTURE

3.1 Curriculum Composition

No.	Curriculum Components	Number of Credits (New)	Credit Distribution (%/Total Credits)
I	GENERAL EDUCATION	27	22%
I.1	<i>University Core Requirement</i>	12	9.8%
I.2	<i>Distributional Requirement</i>	12	9.8%
I.3	<i>Co-curricular Learning</i>	3	2.4%
II	NATIONAL DEFENSE EDUCATION		
III	PROFESSIONAL EDUCATION	96	78%
III.1	<i>College Core Requirement</i>	41	33.3%
III.2	<i>Major Core Requirement</i>	15	12.2%
III.3	<i>Major Foundation Requirement</i>	15	12.2%
III.4	<i>Area of Concentration (Elective)</i>	12	9.8%
III.5	<i>Free Electives (minor*)</i>	7 (15*)	5.6%
III.6	<i>Internship/Co-op</i>	Non-credit (640 hours)	
III.7	<i>Capstone Design</i>	6	4.9%
	TOTAL	123 (131*)	100%

* *Instead of taking 7 credits of free electives, students have an option of taking 15 credits to fulfill the requirements of a minor. Free electives can be any courses offered by CECS or the other colleges at VinUniversity.*

3.2 Courses and Credit Distribution by Courses

No	Course code	Name of Courses	Total Credit	Credit Allocation	
				Theory	Practice
I	GENERAL EDUCATION (GenED)		27		
I.1	University Core Requirement		12		
1	ENGL1011	Fundamentals of Academic Writing	3		
2	ENTR1021	Agile Innovation and Entrepreneurship	3		
3	LEAD1031	Leadership and Teambuilding Bootcamp	2		
4	THINK1010	Critical and Creative Thinking (1)	2		
5	HASS1070	Cross Cultural Navigation (2)	2		
6	VCOR1021/ 22	Healthy Lifestyle 1,2 (3)	Non-credit required (45 hrs)		
I.2	Distributional Requirement		12		
7	HASS1010	Marxism-Leninism Political Economy (Philosophy, Science and Society) (4)	3		
8	HASS1020	Marxism-Leninism Philosophy (Global Political Economy) (5)	2		
9	HASS1030	Scientific Socialism (Politics and Social Change) (6)	2		
10	HASS1041/ 1042	Ho Chi Minh Ideology (Vietnam: History and Cultures II) (7)	2		
11	HASS1050	History of the Communist Party (Vietnam: History and Cultures I) (8)	2		
12	ARTS1010/ MUSI1010	Arts Courses (9) (Students select one course in the pool, i.e. ARTS1010, MUSI1010)	1		
I.3	Co-curricular Learning (10)		3		
13	VCOR1012A /B	OASIS (Orientation, Advising, Skills, Identity & Diversity, and Spirit of Pay-it-Forward)	Non-credit		
14	COSL1010	Community Service Learning	3		

No	Course code	Name of Courses	Total Credit	Credit Allocation	
				Theory	Practice
II	NATIONAL DEFENSE EDUCATION (as required by the Government for Vietnamese citizens)		165 hrs		
III	PROFESSIONAL EDUCATION				
III.1	College Core Requirement		41		
15	MATH2010	Probability and Statistics	4	3	1
16	MATH1010	Calculus I	4	3	1
17	MATH1020	Calculus II	4	3	1
18	MATH2030	Differential Equations	3	2	1
19	MATH2050	Linear Algebra	4	3	1
20	PHYS1010	Physics I	4	3	1
21	PHYS2020	Physics II	3	2	1
22	PHYS2030	Physics III	2	2	0
23	CHEM2010	Chemistry	3	2	1
24	CECS1010	Introduction to Engineering and Computer Science	4	2	2
25	COMP1010	Introduction to Programming	4	2	2
26	LAW3010	Introduction to Law	2	2	
III.2	Major Core requirement		15		
27	ELEC2010	Introduction to Circuits for Electrical Engineers	4	3	1
28	ELEC2020	Signals and Information	4	3	1
29	ELEC3010	Digital Logic and Computer Organization	4	3	1
30	ELEC2030	Computer Systems Programming	3	3	0
III.3	Major Foundation requirement		15		
31	ELEC3020	Electromagnetic Fields and Waves	4	3	1
32	ELEC4010	Introduction to Microelectronics	4	3	1
33	ELEC4020	Embedded Systems	4	3	1
34	ELEC3030	Intelligent Physical Systems (Interdisciplinary Engineering Design Project)	3	2	1 (lab + project)
III.4	Area of Concentration (Elective) (Select one)				
III.4.1	Communications and Signal Processing		12		
1	ELEC3040	Digital Signal and Image Processing	4	3	1 (project)

No	Course code	Name of Courses	Total Credit	Credit Allocation	
				Theory	Practice
2	ELEC4030	Computer Networks and Telecommunications	4	3	1
3	ELEC4040	Digital Communication System Design	4	3	1
III.4.2	Control and Automation		12		
1	ELEC3050	Control Systems	4	3	1
2	ELEC4050	Control System Theory and Design	4	3	1
3	ELEC4060	Robotics and Automation	4	3	1
III.4.3	Power and Clean Energy		12		
1	ELEC3060	Introduction to Electric Power Systems	3	2	1
2	ELEC3070	Green Electric Energy	3	2	1
3	ELEC4070	Power Electronics	3	2	1
4	ELEC4080	Modern Distribution Systems with Renewable Resources	3	3	0
III.5	Free Electives (or minor) (students may select courses from the list below or be free to select any courses offered by VinUni)		7 (15)		
1	CECS2020	Seminar on Advanced Topics in Engineering and Computer Science	1		1
2	UROP1010/ UROP1020/ UROP1030/ UROP1040	Undergraduate Research Opportunities Program 1/2/3/4	1		1
3	UROP1011/ UROP1021/ UROP1031/ UROP1041	Undergraduate Research Opportunities Program 1/2/3/4	0		
III.6	Internship				
	ELEC3870	Internship	640 hrs		
III.7	Capstone Design		6		
	ELEC4890	Capstone design	6		6

Note:

General notes:

(1) Critical thinking course supplements for critical and creative framework.

(2) Cross-Cultural Navigation supplements for leadership framework, global awareness which play as university core requirements.

(3) To fulfill MOET's requirement of Physical Education and university core requirement. MOET requirement for physical education is a 45 hour course (equivalent to 3 credits) but not counted in total credits.

(4 to 8) to fulfill Vietnam Ministry of Education and Training (MOET)'s requirements on politic and ideology education for Vietnamese undergraduate students.

(9) Arts courses:

Students can select either ARTS1010 or MUSI1010 to fulfill the art component requirement.

Students may take other art courses (i.e ARTS1010 or MUSI1010, etc) as elective one(s).

(10) Separation of Community Service Learning (CSL) from OASIS: OASIS will now be managed by the Student Affairs Management (SAM) Office and will be a skills and experience-based non-credit part of General Education. Students will be required to complete aspects of OASIS at different times throughout the 4 years. CSL will now be a standalone course and be worth 3 credit.

Note for international students:

- International students are not required to take ideology courses, including HASS1010, HASS1020, HASS1030, HASS1041/42, HASS1050, however, students can select it as elective courses.

- International students are exempted from National Defense Education. However, they are required to register for at least one of the following courses to make up for NDE:

- History of the Communist Party (Vietnam: History and Cultures I)*
- Ho Chi Minh Ideology (Vietnam: History and Cultures II)*
- Vietnamese Language*

- International students can choose other elective courses to meet the required credits for graduation (for example, at least 120 credits for a 4-year program and at least 180 credits for a 6-year program).

3.3 Curriculum Planner

There are two tracks: Main track and Pathway English track (for students who need to improve English requirement)

Course flow - Main track

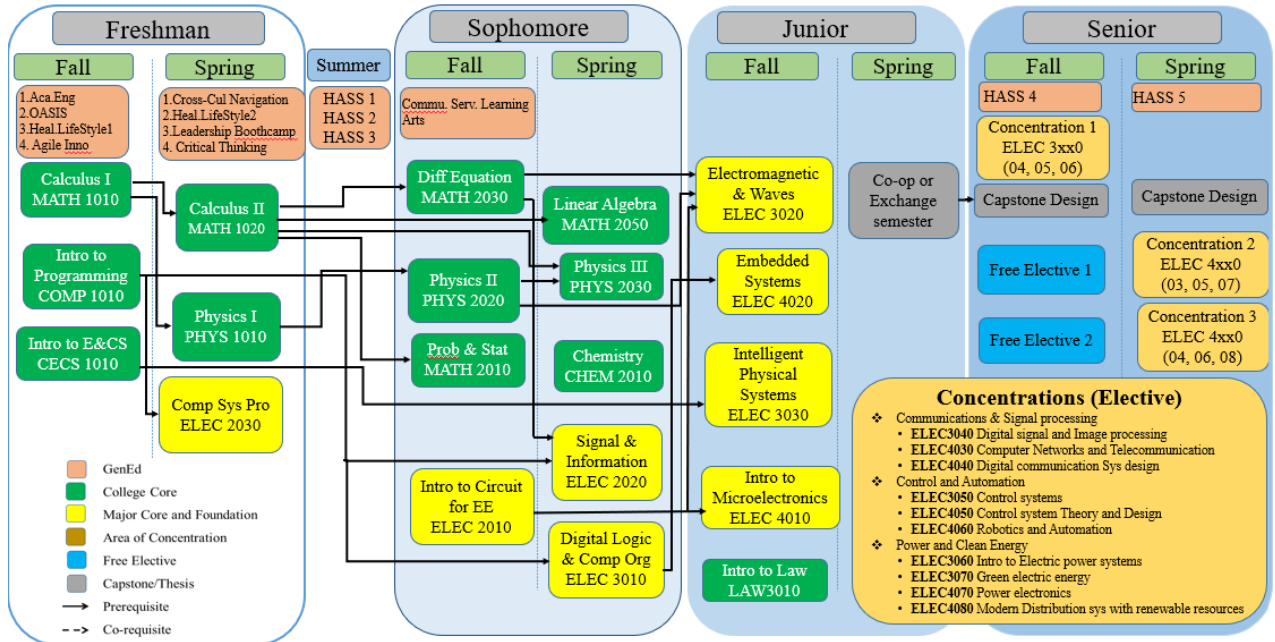

Course flow - Pathway track

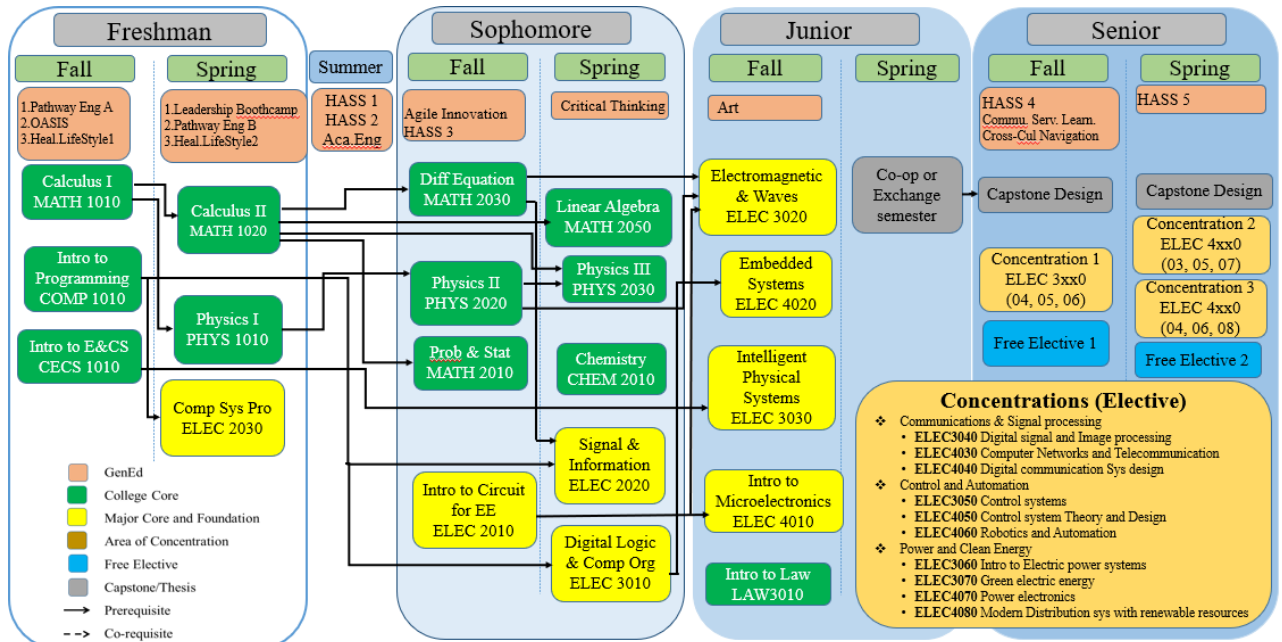

Main track:

Undergraduate Electrical Engineering Curriculum		GenED Core	College Core	Major core and Foundation	Area of Concentration	Free Electives/ Minor	Practice/ Internship	Graduation Thesis/ Capstone
Year 1 Fall	Calculus I		4					
	Introduction to Programming		4					
	Introduction to Engineering and CS		4					
	Agile Innovation & Entrepreneurship	3						
	Fundamentals of Academic Writing	3						
	OASIS	Non-Credit						
	Healthy Lifestyle 1	Non-Credit						
Total Semester Credits			18					
Year 1 Spring	Calculus II		4					
	Physics I		4					
	Computer Systems Programming			3				
	Cross-cultural Navigation	2						
	Leadership and Teambuilding Bootcamp	2						
	Critical and Creative Thinking	2						
	Healthy Lifestyle 2	Non-Credit						
Total Semester Credits			17					
Summer 1	HASS course 1	3						
	HASS course 2	2						
	HASS course 3	2						
Total Semester Credits			7					
Year 2 Fall	Differential Equations		3					
	Physics II		3					
	Probability and Statistics		4					
	Community Service Learning	3						
	Arts	1						
	Introduction to Circuits for Electrical Engineers			4				
Total Semester Credits			18					
Year 2 Spring	Linear Algebra		4					
	Physics III		2					
	Chemistry		3					
	Signals and Information			4				
	Digital Logic and Computer Organization			4				
Total Semester Credits			17					
Summer 2	Internship or exchange program						Non Credit	
Year 3 Fall	Embedded Systems			4				
	Electromagnetic Fields and Waves			4				
	Intelligent Physical Systems (interdisciplinary Design project)			3				
	Introduction to Microelectronics			4				
	Introduction to Law		2					
Total Semester Credits			17					
Year 3 Spring	Co-op semester (No credit)							
Total Semester Credits			0					
Summer 3	Internship or exchange						No credit	
Year 4 Fall	Capstone Design							3
	Concentration 1				4			
	HASS course 4	2						
	Free Elective 1					3		
	Free Elective 2					4		
Total Semester Credits			16					
Year 4 Spring	Capstone Design							3
	HASS course 5	2						
	Concentration 2				4			
	Concentration 3				4			
Total Semester Credits			13					

Total Program Credit Hours 123

Credit Hour Distribution	27	41	30	12	7	0	6
--------------------------	----	----	----	----	---	---	---

Pathway track:

Undergraduate Electrical Engineering Curriculum		GenED Core	College Core	Major core and Foundation	Area of Concentration	Free Electives/ Minor	Practice/ Internship	Graduation Thesis/ Capstone
Year 1 Fall	Calculus I		4					
	Introduction to Programming		4					
	Introduction to Engineering and CS		4					
	Pathway English Advanced A	Non-Credit						
	OASIS	Non-Credit						
	Healthy Lifestyle 1	Non-Credit						
Total Semester Credits			12					
Year 1 Spring	Calculus II		4					
	Physics I		4					
	Computer System Programming			3				
	Leadership Boothcamp	2						
	Pathway English Advanced B	Non-Credit						
	Healthy Lifestyle 2	Non-Credit						
Total Semester Credits			13					
Summer 1	HASS course 1	3						
	HASS course 2	2						
	Fundamentals of Academic Writing	3						
Total Semester Credits			8					
Year 2 Fall	Differential Equations		3					
	Physics II		3					
	Probability and Statistics		4					
	Agile Innovation & Entrepreneurship	3						
	HASS course 3	2						
	Introduction to Circuits for Electrical Engineers			4				
Total Semester Credits			19					
Year 2 Spring	Linear Algebra		4					
	Physics III		2					
	Chemistry		3					
	Critical and Creative Thinking	2						
	Signals and Information			4				
	Digital Logics and Computer Organization			4				
Total Semester Credits			19					
Summer 2	Internship or exchange program						Non Credit	
Year 3 Fall	Embedded Systems			4				
	Electromagnetic Fields and Waves			4				
	Intelligent Physical Systems (interdisciplinary Design project)			3				
	Introduction to Microelectronics			4				
	Introduction to Law		2					
	Art	1						
Total Semester Credits			18					
Year 3 Spring	Co-op semester (No credit)							
Total Semester Credits			0					
Summer 3	Internship or exchange						No credit	
Year 4 Fall	Capstone Design							3
	Concentration 1				4			
	HASS course 4	2						
	Community Learning Service	3						
	Cross-cultural Navigation	2						
	Free Elective 1					3		
Total Semester Credits			17					
Year 4 Spring	Capstone Design							3
	Concentration 2				4			
	Concentration 3				4			
	Free Elective 2					4		
		HASS course 5	2					
Total Semester Credits			17					

Total Program Credit Hours 123

Credit Hour Distribution	27	41	30	12	7	0	6
---------------------------------	-----------	-----------	-----------	-----------	----------	----------	----------

3.4 Course Descriptions

ENGL1011 Fundamentals of Academic Writing

3 credits

Pre-requisite: None

The course begins by focusing on academic writing at the essay level, helping students understand the aspects which make academic writing different from other styles of writing. Students will develop confidence in critically evaluating information and responding with sound argumentation and logical development of ideas. In this early stage of the course, students will strengthen core academic literacies including critical reading, summarizing, paraphrasing, and peer feedback. As the course progresses, the focus shifts towards incorporating secondary research into writing, developing students' abilities to evaluate credible sources and synthesize information with their original ideas to have a voice in the broader academic community and develop authority in communicating ideas to a wider audience. Students will develop essential academic literacies such as searching skills, strategies for reading journal articles, synthesizing information, citing and referencing, reference management, and other secondary research techniques. Finally, students will summarize key information they have found in the form of an academic poster, which is a common medium for visually communicating information in academic contexts.

Fundamentals of Academic Writing places active learning at the core, and every lesson includes practical activities to help students apply these skills. This course follows a process writing approach, which includes drafting, peer and teacher feedback, reflection, and revision before producing the final piece of writing. Working together in interdisciplinary groups, students will present, critique, and revise their work with their peers to build autonomy, write for an audience, and gain confidence as writers.

ENTR1021 Agile Innovation and Entrepreneurship

3 credits

Pre-requisite: None

The purpose of this course is to provide students with a basic understanding of the entrepreneurial and innovation mindset and provide students the opportunity to learn about and develop skills and behaviors correlated with impactful entrepreneurs and innovators. Skills to be developed – through lecturing and in-class discussions, plus coaching on assignments and in-class exercises – include observation of real-world facts, identifying status-quos or problems, identifying core causes leading to status-quos, and to discover original ways to remove causes or to solve problems; networking with people to identify technological contributions, optimizing creativity, seeking feedback, and prototyping or mockup design. The pedagogical outcomes of this course include (i) development of creativity & out-of-

the-box thinking, (ii) critical thinking through observation and abstractions, (iii) entrepreneurial mindset and (iv) teamwork on a social or environmental issue. As part of the course all students will engage in a 2-day hackathon to present and discuss optimization of team's solution to a real-world social or environmental problem. The course is intended for a mix of students from various academic disciplines, such as medicine, nursing, engineering, business, real estate, and hospitality.

LEAD1031 Leadership and Team building Bootcamp

2 credits

Pre-requisites: None

This course is designed as a required course for freshmen to help the students' leadership development by introducing the basic concepts of leadership and organizational behavior. This course has one big goal for you: to practice and apply concepts and techniques learned in the class and your life to various scenarios. This course is also intended to provide an overview of leadership trends rather than to emphasize every detail and in-depth review of academic studies. Understanding a landscape of leadership will be possible under the structure of four modules: (1) Leader as a decision-maker, (2) Leader as a problem solver, (3) Leader as a designer, and (4) Leader as a game-changer. A leader in this turbulent world is expected to be the final decision-maker to find a creative solution for difficult challenges and will need to organize a group of people with a formal and informal system. Leadership Development offers a safe place for your learning of leadership. Practice, try, fail, and try again! This is the philosophy of this course.

The Boot Camp instills foundational leadership values and skills into students, while bringing the class together, building lasting cohesion, and creating esprit de corps. Students will learn and apply basic leadership concepts and skills through hands-on and experiential learning. Organized into individual and team-based events, the students will have to work individually and together to solve complex and dynamic problems taken from the military, government, and business sectors. This includes but is not limited to: conducting long distance land navigation, negotiating physical obstacle courses, analyzing leadership case studies, and much more. From developing self-awareness and thinking critically to innovating ideas and displaying resilience, students will learn critical elements of Self, Interpersonal, and Team Leadership. Following this course, students will gain a foundational understanding of key elements of leadership and better understand their strengths and how to effectively work in teams and organizations.

THINK1010 Critical & Creative Thinking

2 credits

Pre-requisites: None

Developing your own ideas in a logical and critical manner is an essential part of being a student in higher education. In this course you will learn about the nature of argumentation, how to evaluate arguments, uncover hidden premises, and sharpen your own thinking skills. We will start by looking at the difference between arguments and non-arguments and why being able to present an argument is such an important skill. Then we will look at different kinds of arguments, such as deduction, induction, and arguments from inference to the best explanation. Not all arguments are made equal. Some arguments are irrefutable - others barely convincing - and others still completely misleading. We will look at how you can assess the quality of an argument and avoid common logical pitfalls. Finally, we will finish by looking at some philosophical puzzles and paradoxes involving logic and reasoning including Hume's notorious problem of induction and the Sorites paradox.

HASS1070 Cross Cultural Navigation

2 credits

Pre-requisite: None

This course aims to equip students an understanding of one aspect of the so-called “global experience” and/or inter-cultural sensitivity, so that students can become knowledgeable about the ways in which individual identities, values, and perceptions and biases are shaped by cultures across the continentals through acquiring knowledge of theories practice related to the impact of culture in our daily ecologies in local and global contexts. In the end, students can identify and understand the inter-sectional of one’s own and others’ cultural identities in order to reflect on how various cultural concepts apply to your own life, communication and various areas of study.

VCOR1021/22 Healthy Lifestyle 1, 2

Credit: non-credit, required min 45 hours across Year 1

Pre-requisite: None

“Healthy Lifestyle” is a mandatory and non-credit bearing course of the General Education Program. Undergraduate students are required to enroll in this course to fulfill part of the graduation requirements and are expected to complete it by the end of their first-year study. This course provides the essential knowledge, skills and practicum lessons (exercise/sport classes), whereby students are able to develop a suitable approach in attaining a physically, mentally, socially and spiritually healthy lifestyle.

Specifically, this course provides students with the knowledge to make better choices during their daily routines to build a healthy lifestyle. A healthy lifestyle includes physical wellbeing, psychosocial, and spiritual health. Students receive mentorship that guides and shapes their perspective, showcasing the importance of

having a well-balanced life. Components of a healthy lifestyle will be discussed as a process and science that allows students to have a greater understanding of what it takes to achieve their goals for overall wellbeing. Nutrition and diet will be taught to dispel the myths about how and what you should eat to achieve desired health results. Having a healthy mind, healthy body, clarity of thought and the ability to effectively process information are key trademarks of a healthy lifestyle.

This course emphasizes practical application of the learned concepts in order to integrate subject matter into students' current daily routines and throughout life. The majority of coursework will be held in different environments and venues in order to expose students to the many varieties of fitness tools and resources to maintain a healthy foundation.

HASS1010 Marxism-Leninism Philosophy (Philosophy Science and Society)

3 credits

Pre-requisite: NA

Philosophy Science and Society is one of four courses in the General Education Program forming the ideology/national education component required for higher education curriculum as directed by the Ministry of Education & Training, Socialist Republic of Vietnam. These four courses are written to achieve the primary objective of helping students understand core values of both country and university through objective and critical academic lenses in a global context. As these courses will be taught in English to students for whom English is mainly a second language at VinUniversity, each course is designed to be delivered in the spirit of content-based language learning approach to help students both develop English language competency (focusing on speaking, listening and reading) and basic understanding of the content. Philosophy, Science & Society (PSS) provides students with a broad survey of key ideas in Philosophy, its relevance to society and the way we think we understand the world, or to put it broadly, "science." We begin the course with an overview of the role of Philosophy and Metaphysics as we embark on this journey of critically re-examining the way we look at our world. In the second part of the course, we take a deep dive into questions of Epistemology, based on which students can orient and develop their creative thinking, philosophy of humanity and action. We follow up with an exploration of trends that came into being with the "social turn" of epistemology found in the critical works of Thomas Kuhn and later in the burgeoning body of works clustered as Sociology of Science. Following this radical re-thinking, we return to the fundamental questions about humanity posed in Social Philosophy and Ethics, to round up our critical inquiry of the complex relationship among philosophy, science and society.

HASS1020 Marxism-Leninism Political Economy (Global Political Economy)

2 credits

Pre-requisite: NA

Global Political Economy: Vietnam-Region-The World is one of four courses in the General Education Program forming the ideology/national education component required for higher education curriculum as directed by the Ministry of Education & Training, Socialist Republic of Vietnam. These four courses are written to achieve the primary objective of helping students understand core values of both country and university through objective and critical academic lenses in a global context. This course is designed to help students develop a critical lens to understand social reality and social issues, including pressing questions, such as: What is Vietnam's place in the world? What are the opportunities and challenges for Vietnam in the current configuration of the global political economy? To do so, we begin with a brief introduction to the study of political economy, informed by different persuasions in Marx-Leninism, political science, economic, sociology, anthropology and history. Students will gain a nuanced understanding of this interdisciplinary field through hands-on workshops and exercises on the principles of scientific and logical arguments. The second part of this course will focus on specific issues related to globalization and international integration. In particular, we focus on the role of development, modernization, and regional development in Vietnam's prospects in the world. Our case studies pay special attention to the immediate regions surrounding Vietnam, namely ASEAN, East Asia (in particular, China) and South Asia. In the third and final part of this course, we examine the expressions of global inequality and consider how individuals and communities within Vietnam can move forward in an ever-globalizing world.

HASS1030 Scientific Socialism (Politics and Social Change)

2 credits

Pre-requisite: NA

Assuming a basic, strong, and even pivotal relationship between society and politics, the course Politics and Social Change will guide participants to a deep understanding of that relationship in Vietnam and the wider Asian region in the 20th and 21st centuries. The course explores key concepts of politics and social change, and in explication of those concepts, examine the dynamics of politics and social change in concrete terms.

What can be learned?

Students at the end of course will become familiar with the concepts of politics and social change of Vietnam. Students will also understand and compare Vietnam with national development efforts elsewhere in Asia. Finally, they will become familiar with major political and international relations developments from the 20th century.

The medium of instruction helps students to both develop English language competency (focusing on speaking, and articulation, reading) and discourse skills through continuous practice with classmates and instructor.

Broad outlines

The course begins with a basic appreciation of the concepts of politics and social change, moving into Marxism-Leninism and its application to understanding politics & social change, and extending into how Ho Chi Minh Thought applies Marxism-Leninism and also stands apart as a set of national and contextual ideas and practices. The processes of politics and social change of other countries in the Asia-Pacific are then explored for comparison and contrast.

Medium of learning

The guiding principle for learning at the Vin Uni is active learning. This approach engages students to be active in the learning process with methods that are more than, not without, the traditional base of lectures and tutorials. The instructor or teacher plays the role of facilitator and provides the environment where students responsibly and actively acquire as much as possible, rather than are passively given, the learning points that the course desires.

Participants in this course will learn and share through a mix of lectures, tutorials, non-judgmental journal writing, presentations, and learning to collaborate with others through group projects. The learning environment should be safe, frank, friendly, collaborative, and enlightening.

The weekly lists of readings are divided into two types. Basic readings are recommended, and students should at least complete one for each week. Students who wish to do more can pick up the other basic and optional/additional readings.

HASS1041/1042 Ho Chi Minh Ideology (Vietnam: History and Culture II)

2 credits

Pre-requisite: NA

Vietnam History and Culture since 1858 is continuation of the first period (from ancient time to 1858) and covers the period from 1858 until today.

The main objective of the course is to analyze the development of Vietnam and its people from 1858 when France attacked and colonized VN through two Indochina wars (1946-1965) and (1954-1975) until today as Vietnam reunified and reformed and integrated into international system.

Due to its strategic geopolitical position, Vietnam has long been a global crossroads. So, this course tries to show as much as possible the parallels, interactions between Vietnam history and events and that happened in the world's stage.

The course also aims to reflect Vietnam history and culture through the central figure of Ho Chi Minh (1890-1969), the most famous Vietnamese during this period. His life and career reflected the development of the very period of Vietnam history.

Students are encouraged to do research himself to have broader view, discover new historical details.

HASS1050 History of the Communist Party (Vietnam: History and Culture I)

2 credits

Pre-requisite: NA

The great American humorist and writer Mark Twain once said, “History doesn’t repeat itself, but it often rhymes.” This course takes as its point of departure the possibility of using those rhymes of the past to better help us navigate our present and future. What lessons can we draw? As future businesspeople, health care professionals, engineers, and computer scientists, these lessons have far more relevance than you may imagine.

Vietnam History and Culture (I) examines Vietnamese history and cultural production from its early origins to 1858 and the French Colonial project. The curriculum is divided into five units. We begin the curriculum by considering the study of both history and culture from theoretical perspectives and consider what these mean in the Vietnamese context. Just what are “History” and “culture”? What does it mean to be Vietnamese? In the second unit, we consider the ancient construction of Vietnamese history and cultural production. The third portion of the course

examines the Lý and Trần dynasties as well as the Ming Occupation. Fourth, we explore the movement of Vietnamese people southward and the Tây Sơn Rebellion. And finally, fifth, we assess the unification of Vietnam under the Nguyễn and what is to come.

Too often Vietnamese are portrayed in history as vessels upon which events happen to them. This course treats the Vietnamese as agents of their history, grappling with big questions and great problems. We also explore the Vietnamese people’s historical willingness to learn from and integrate foreign ideas and instruments to further develop the Vietnamese culture. To this end, we will wrestle with questions such as: What are the forces that have shaped Vietnamese identity? What drives the worldview(s) of Vietnamese? How has it been transformed over time?

ARTS1010 Arts Appreciation

1 credit

Pre-requisite: NA

Art Appreciation is a one-credit elective course that provides a general introduction to the visual arts, media, techniques, and history. This course takes on interdisciplinary approaches to equip students with a broad knowledge of the historical, practical, philosophical, cultural, and social contexts of the arts in order to help students gain the ability to articulate their understanding and interpretation of

the arts. This course introduces students to aspects of arts research and curation, as well as elements, media, and methods used in creative processes. The application of the arts, especially visual arts in daily life and in the field of business, technology, and medicine is explored in this course. This course also aims to develop students' appreciation for Vietnam arts and visual art forms by providing them with opportunities to explore the diversity and richness of what Vietnam has to offer in terms of the arts.

This course offers students opportunities to learn about how art is created and how it evolves over time; it would cultivate and enrich students' artistic senses, experience, and enjoyment of different forms of arts even if the student is not an artist or does not have an ability to draw/paint. In addition, this course fosters and supports students' development of oral and written presentation and communication, critical and analytical thinking, and multicultural perspectives.

This course does not require students to have any prerequisite experience in art theory or practice. Rather, it is a beginning-level course to help students familiarize themselves with the different types of arts, as well as learn how to observe, appreciate, speak, write intellectually about art. Furthermore, the course helps students to think about how art can be integrated and applied in their daily lives and their own fields of interest.

MUSI1010 Music Appreciation

1 credit

Pre-requisite: NA

This course offers students opportunities to learn about how music is created and how it evolves over time; it would enrich students' musical sense, experience, and enjoyment of all types of music even if the student is not a musician. In addition, this course fosters and supports students' development of oral and written presentation and communication, critical and analytical thinking, and multicultural perspectives.

Specifically, students taking this course will have the opportunity to explore the history of music, from the primitive musical forms through contemporary pieces around the world. Forms and genres of music include classical, jazz, theatrical music, gospel, folk, soul, blues, Latin rhythms, country, rock & roll, and hip hop. Various arrays of Vietnamese music (traditional, contemporary, theatrical, V-pop) are also discussed in this course. The course explores the relationship between music and people's everyday life and social movements, and its cultural significance. Digital music and the evolution of the Internet and AI impacting music industry, music distribution, and global music access are also an important part of this course.

This course does not require students to have any prerequisite experience in musical theory or performance; i.e. students are not required to be able to sight-read sheet music, or play any musical instrument. Rather, it helps students become an active and intellectual music listener, as well as it helps students to think further on how

music can be integrated and applied in the daily lives and their own fields of interest. This course is delivered in class and outside class environment if appropriate.

VCOR1012A/B OASIS - Orientation, Advising, Skills, Identity & Diversity, and Spirit of Pay it Forward

Non-credit

Pre-requisite: NA

OASIS, which stands for Orientation, Advising, Skills, Identity & Diversity, and Spirit of Pay it Forward, is an integral, non-credit-bearing mandatory component of the Co-curriculum Program and plays an important role as one of the graduation criteria.

OASIS is a distinctive signature program of VinUni that holds a registered trademark. Its primary objective is to cultivate a self-leadership mindset and equips students with essential skills, facilitating their transformation from high school students into effective university scholars, responsible global citizens, and be ready for future career. OASIS is implemented in the first 4 years of bachelor's degree to ensure there is enough time for students to reflect and practice their own self-leadership development, especially in developing essential qualities for work and life, including self-confidence, self-esteem, self-determination, and self-control.

COSL1010 Community Service Learning

3 credits

Pre-requisite: none

VinUniversity aims to nurture students to become both competent professionals and responsible citizens making contributions to their professions and the community. Community Service Learning (CSL) provides students with the opportunities to serve the community and to learn how to apply their professional knowledge in bettering the lives of the public. As part of CSL, students must take the 1 credit Introduction to Service-Learning course (equivalent to 15 hours) and fulfill the remaining 30 hours of CSL doing independent volunteer work.

CSL is increasingly recognized as a method for educating students to become socially responsible citizens. Many universities over the world have incorporated CSL in their academic undergraduate programs to varying degrees and in a variety of forms. CSL can be a differentiating factor for VinUni students as they become global citizens. "Service-learning is a form of experiential education in which students engage in activities that address human and community needs, together with structured opportunities for reflection designed to achieve desired academic learning outcomes" (Service-Learning Essentials, Jacoby 2014; pg.2). Note: Activities must primarily take place off VinUni campus and within the community.

All undergraduate students are required to first take the 1-credit bearing course entitled: Introduction to Service Learning and then do volunteer work or continuing

education/independent study to complete 30 + hours of an independent CSL activity (i.e., volunteer with a local NGO).

LAW3010 Introduction to Law

2 credits

Pre-requisites: None

Course Description:

Introduction to Law is designed to provide students with a foundational understanding of legal principles and their application within the context of engineering practice. First, the course introduces legal systems and sources of law including an overview of different legal systems, sources of law (e.g., statutes, regulations, case law), and the hierarchy of legal authority. Then, the course will explore the intersection of law and engineering fields, emphasizing the legal frameworks, regulations, and ethical considerations that engineers encounter throughout their careers. The topics covered but are not limited to contracts and agreements, intellectual property rights, health and safety regulations, environmental laws, standards compliance, professional codes of conduct, conflicts of interest, and ethical decision-making in engineering practice. The course is taught through a combination of lectures, case studies, discussions, and practical exercises.

MATH1010 Calculus I

4 credits

Pre-requisites: High school three years high school mathematics, including trigonometry and logarithms, and at least one course in differential and integral calculus

This course teaches techniques of integration, finding areas and volumes by integration, exponential growth, partial fractions, infinite sequences and series, tests of convergence, and power series.

MATH1020 Calculus II

4 credits

Pre-requisites: Calculus I

This course gives an introduction to multivariable calculus. Topics include partial derivatives, double and triple integrals, line and surface integrals, vector fields, Green's theorem, Stokes' theorem, and the divergence theorem.

MATH2030 Differential Equations

3 credits

Pre-requisites: Calculus II

Taking with Linear Algebra simultaneously is not recommended.

This course gives an introduction to ordinary and partial differential equations. Topics include first order equations (separable, linear, homogeneous, exact); mathematical modeling (e.g., population growth, terminal velocity); qualitative methods (slope fields, phase plots, equilibria and stability); numerical methods; second order equations (method of undetermined coefficients, application to oscillations and resonance, boundary value problems and eigenvalues); and Fourier series. A substantial part of this course involves partial differential equations, such as the heat equation, the wave equation, and Laplace's equation.

MATH2050 Linear Algebra

4 credits

Pre-requisites: Calculus II

Taking with Differential Equations simultaneously is not recommended.

This course teaches linear algebra and its applications. Topics include matrices, determinants, vector spaces, eigenvalues and eigenvectors, orthogonality and inner product spaces; applications include brief introductions to difference equations, Markov chains, and systems of linear ordinary differential equations. This course also includes computer use in solving problems.

MATH2010 Probability and Statistics

4 credits

Pre-requisites: Calculus II

This course gives students a working knowledge of basic probability and statistics and their application to engineering including computer analysis of data and simulation. Topics include random variables, probability distributions, expectation, estimation, testing, experimental design, quality control, and regression.

PHYS1010 Physics I

4 credits

Pre-requisites: Calculus I (integration, finding areas and volumes by integration, exponential growth, partial fractions, infinite sequences and series, tests of convergence, and power series).

This course covers the mechanics of particles with focus on kinematics, dynamics, conservation laws, central force fields, periodic motion. Mechanics of many-particle systems: center of mass, rotational mechanics of a rigid body, rotational equilibrium, and fluid mechanics. Temperature, heat, the laws of thermodynamics.

PHYS2020 Physics II

3 credits

Pre-requisites: Physics I

This course covers electrostatics, the behavior of matter in electric fields, DC circuits, magnetic fields, Faraday's law, AC circuits, and electromagnetic waves

PHYS2030 Physics III: Oscillations, Waves, and Quantum Physics

2 credits

Pre-requisites: Physics II (Electromagnetism), Calculus II

This course covers the physics of oscillations and wave phenomena, including driven oscillations and resonance, mechanical waves, sound waves, electromagnetic waves, standing waves, Doppler effect, polarization, wave reflection and transmission, interference, diffraction, geometric optics and optical instruments, wave properties of particles, particles in potential wells, light emission and absorption, and quantum tunneling.

CHEM2010 Chemistry

3 credits

Pre-requisites: High school chemistry

This course covers basic chemical concepts, such as reactivity and bonding of molecules, introductory quantum mechanics, and intermolecular forces in liquids and solids and gases. Attention will be focused on aspects and applications of chemistry most pertinent to engineering.

CECS1010 Introduction to Engineering and Computer Science

4 credits

Pre-requisites: None

This course provides a general introduction to the engineering design process—spanning core topics from problem definition through prototyping and testing, as well as other important considerations such as sustainability, failure analysis, and engineering economics. This course also emphasizes multidisciplinary design via a design project (e.g., design a line following robot) which involves students from different majors of college of engineering and computer science.

COMP1010 Introduction to Programming

4 credits

Pre-requisites: None

This course teaches programming and problem-solving using Python. Emphasizes principles of software development, style, and testing. Topics include procedures and functions, iteration, recursion, arrays and vectors, strings, an operational model of procedure and function calls, algorithms, exceptions, object-oriented programming, and GUIs (graphical user interfaces).

ELEC2010 Introduction to Circuits for Electrical Engineers

4 credits

Co-requisites: Differential Equations and Physics II

This course establishes the fundamental properties of circuits with application to modern electronics. Topics include circuit analysis methods, operational amplifiers, basic filter circuits, and elementary transistor principles. The laboratory experiments are coupled closely with the lectures.

ELEC2020 Signals and Information

4 credits

Pre-requisites: Differential Equations, Introduction to Programming, *Co-requisite:* Linear Algebra

This course teaches introduction to signal processing. Topics include frequency-based representations: Fourier analysis and synthesis; discrete-time linear systems: input/output relationships, filtering, spectral response; analog-to-digital and digital-to-analog conversion; continuous time signals and linear time-invariant systems: frequency response and continuous-time Fourier transform.

ELEC3010 Digital Logic and Computer Organization

4 credits

Pre-requisites: Introduction to Programming

This course provides an introduction to the design and implementation of digital circuits and microprocessors. Topics include transistor network design, Boolean algebra, combinational circuits, sequential circuits, finite state machine design, processor pipelines, and memory hierarchy. Design methodology using both discrete components and hardware description languages is covered in the laboratory portion of the course.

ELEC2030 Computer Systems Programming

3 credits

Pre-requisites: Introduction to Programming

This course provides a strong foundation in the principles, practices, and art of computer systems programming using the C and C++ programming languages. Students will learn procedural programming in C and how to theoretically analyze and practically implement basic data structures and algorithms. Students will transition to C++ to explore object-oriented, generic, functional, and concurrent programming before exploring advanced data structures and algorithms involving trees, tables, and graphs. Students will explore systems programming using the POSIX standard library. The course includes a series of programming assignments for students to put the principles they have learned into practice.

ELEC3020 Electromagnetic Fields and Waves

4 credits

Pre-requisites: Physics II, Differential equations, Introduction to Circuits for Electrical Engineers

This course covers static, quasi-static, and dynamic electromagnetic fields and waves. Topics include Maxwell's equations (integral and differential forms), fields of charge and current distributions, boundary conditions, fields near conductors, method of images, material polarization and dielectrics; energy, work, and power in electromagnetic systems; wave propagation and polarization, waves in media (dielectrics, conductors, and anisotropic materials); reflection, transmission, and refraction at media interfaces; guided waves in transmission lines, Smith charts, transients; metallic and dielectric waveguides; radiation and antennas, antenna arrays, electric circuits for transmission and reception, aperture antennas and diffraction.

ELEC4010 Introduction to Microelectronics

4 credits

Pre-requisites: Introduction to Circuits for Electrical Engineers

This course introduces the basic devices and circuits in modern microelectronics. Students learn not only basic structures and operations of semiconductor devices through simple models (diodes, CMOS, and BJT) but also how to analyze and design basic transistor modules in digital and analog circuits including biasing, amplifiers, filters, logic gates, and memory. The course introduces intuitive design methods to map circuit specifications to transistor topology, as well as first-order time-constant estimation. SPICE and measurement labs accompany the progress in lectures for hands-on experiences.

ELEC4020 Embedded Systems

4 credits

Pre-requisites: Digital Logic and Computer Organization

This course provides an introduction to the design of embedded systems, with an emphasis on understanding the interaction between hardware, software, and the physical world. Topics covered include assembly language programming, interrupts, I/O, concurrency management, scheduling, resource management, and real-time constraints.

ELEC3030 Intelligent Physical Systems

3 credits

Pre-requisites: Introduction to Engineering, Programming language

This is an interdisciplinary design project course which involves students from different engineering and computer science programs. In this course, students will engage in a holistic design approach to Intelligent Physical Systems which can perceive, reason about, and act upon their environment. This course includes topics on algorithms, sensors, actuators, power, and mechanics. Students will learn the value and trade-offs between theory, simulation, and physical implementations, and gain familiarity with rapid prototyping techniques, system debugging, teamwork, leadership skills, time management, and how to disseminate work to a broader audience through wiki-pages.

ELEC3040 Digital Signal and Image Processing

4 credits

Pre-requisites: Signals and Information

This course focuses on developing a toolbox of techniques to process and analyze real-world signals, model them under uncertainty/noise, and make decisions about them. Highlights of the course will include sampling, filtering, multirate signal processing, intro to statistical signal processing including Wiener and Kalman filtering, and the foundations of computer vision. The course will aim to include a broad range of applications including audio/music, imaging, and data analytics. The coursework includes a design project to emphasize design experiences.

ELEC4030 Computer Networks and Telecommunications

4 credits

Pre-requisites: Embedded Systems

This course teaches basic networking with an emphasis on the Internet. Examples of topics include the World Wide Web, Email and Peer to Peer networks, data transmission and data encoding, circuit vs. packet switching, local area network technology, routing and switching, congestion control, network security, wireless

networks, and multimedia. Though the emphasis will be on the Internet, application modules on 4G/5G cellular, WiFi (802.11), and Bluetooth will be presented.

ELEC4040 Digital Communication System Design

4 credits

Pre-requisites: Probability and Statistics, Signals and Information

The course covers communication theory, transceiver algorithms that enable reliable communication, wireless channels, and modern communication standards (such as 3GPP LTE and WiFi). The students will design a working audio-band communication system that relies on orthogonal frequency-division multiplexing (OFDM).

ELEC3050 Control Systems

4 credits

Pre-requisites: Introduction to Circuits for Electrical Engineers

This course covers the analysis and design of control systems with emphasis on modeling, state variable representation, computer solutions, modern design principles, and laboratory techniques. Topics include Modeling and dynamic response, Root locus design method, Frequency response design methods, State-space design.

ELEC4050 Control System Theory and Design

4 credits

Pre-requisites: Control Systems

This course covers System modeling and analysis, System structural properties, Feedback system design, Optimum feedback control, Introduction to the minimum principle.

ELEC4060 Robotics and Automation

4 credits

Pre-requisites: Control Systems

This course introduces fundamental concepts in robotics and applications. Topics include basics of manipulators, coordinate transformation and kinematics, trajectory planning, control techniques, sensors and devices, robot applications in industrial automation.

ELEC3060 Introduction to Electric Power Systems

3 credits

Pre-requisites: Signals and Systems

This course teaches modern electric power system modeling, analysis, and computation with a focus on analysis techniques appropriate for power system modeling, analysis, and power flow computation. Topics include transmission line models, transformers and per unit system, generator models, network matrices, power flow analysis and computation, real and reactive power control, voltage control, economic dispatch.

ELEC3070 Green Electric Energy

3 credits

Pre-requisites: Introduction to Circuits for Electrical Engineers

This course provides a quantitative, practical introduction to a wide range of renewable energy systems. Topics include wind resource and turbines, Photovoltaic Cells, Solar Resource, Photovoltaic Systems, energy and financial performance of green energy projects; integration of green energy into the power grid, Demand Side Management, Economics of Energy Efficiency.

ELEC4070 Power Electronics

3 credits

Pre-requisites: Introduction to Circuits for Electrical Engineers

This course teaches major power electronics concepts, from both systems and components perspectives and design considerations for switching power conversion. Topics include switching conversion and analysis, DC-DC converters, rectifiers and switched capacitor circuits, inverters, power semiconductors in converters, feedback control for converters, control modeling, and design, AC-AC conversion, resonance in converters.

ELEC4080 Modern Distribution Systems with Renewable Resources

3 credits

Pre-requisites: Introduction to Electric Power Systems

This course teaches the operation of modern electric power distribution systems with the integration of renewable energy sources. Topics include the operation of distribution systems, power quality, solar power systems, wind power systems, system efficiency, and cost-effectiveness.

ELEC3870 Practice/Internship

Non-credit course

Pre-requisites: Students must have completed sophomore year.

The professional structured internship offers students opportunities to apply theoretical knowledge to a real-world work environment and know more about companies that students may be interested in joining after graduation. During the internship, students will have the opportunity to discover and/or confirm their career interests, develop their major knowledge and gain valuable professional skills and connections with industry professionals. Students will complete the program under the guidance and support of a company advisor or Principal Investigator (PI), an industry mentor/ project researcher, and a faculty advisor, who will jointly help students to create SMART learning outcomes (specific, measurable, achievable, relevant and time-bound).

ELEC4890 Graduation Thesis/Capstone

6 credits

Pre-requisites: Practice/Internship; Determined by the advisor

This Capstone course is developed for students in the College of Engineering and Computer Science (CECS) to apply technical knowledge and skills acquired in earlier coursework to a project involving actual designs and experiments. Students are strongly encouraged to work on multidiscipline-major topics to produce an end-to-end solution to a complex real-world problem from industry or academia. The assessment methods are formulated from discussions and agreements between the industry and VinUni in accordance with ABET requirements. More specially, the project involves the development of engineering systems or design alternatives, along with testing the implemented systems. The project should focus on advanced technologies, new applications, and their usefulness and benefits in the development of economy and management. In this course, students work in teams of 3 to 5, with at least one student from the Mechanical Engineering (ME) Program and one from the Electrical Engineering (EE) Program, under the supervision of VinUni faculty instructors. Students are enrolled in Capstone I in the first semester to develop or tailor a project proposal and secure instructor approval. In the following semester, they must take Capstone II to complete the project. Students are expected to be present in person for every meeting of the classes in which they are enrolled. They should be able to deliver their work and contribution to the project and engage in professional dialogues about their project during formal presentations.